

VALVOLE A SFERA

V2-V2M-V3

CE Ex II 2 G/D T.F. 03



Valvole a sfera, rating PN 63 in acciaio inox con tenuta PTFE.

Certificate AT.EX. per le zone 1 e 21

Versioni disponibili

- V2: monoblocco F/F GAS/NPT
- V2M: monoblocco M/F GAS
- V3: tre pezzi F/F GAS/NPT o S.W.

V-2

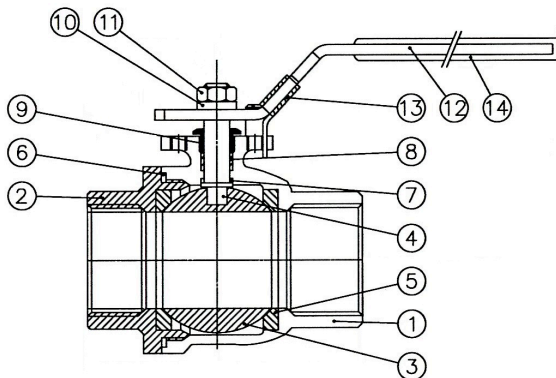

V-2M

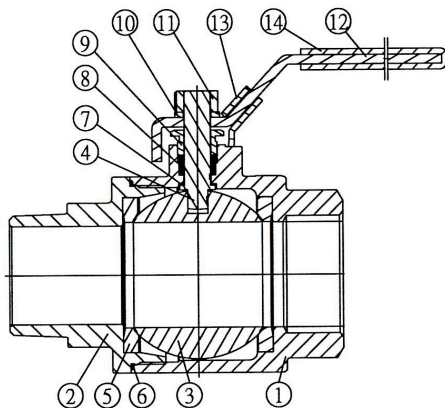

V-3

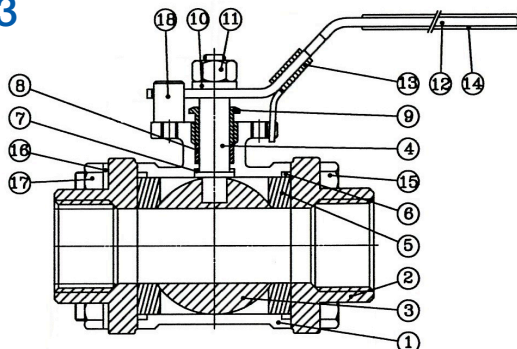

V-2 / V-2M			
N°	PARTICOLARE	MATERIALE	SPECIFICA
1	CORPO	ACCIAIO INOX	AISI 316
2	TERMINALE	ACCIAIO INOX	AISI 316
3	SFERA	ACCIAIO INOX	ASTM A351 CF8M
4	ALBERO	ACCIAIO INOX	AISI 316
5	SEDE	PTFE	-
6	TENUTA CORPO	PTFE	-
7	RONDELLA REGGISPINTA	PTFE	-
8	TENUTA ALBERO	PTFE	-
9	DADO PREMISTOPPA	ACCIAIO INOX	AISI 304
10	RONDELLA	ACCIAIO INOX	AISI 304
11	DADO LEVA	ACCIAIO INOX	AISI 304
12	LEVA	ACCIAIO INOX	AISI 430
13	BLOCCO (*)	ACCIAIO INOX	AISI 430
14	PROTEZIONE	PVC	-

(*) Opzionale

V-3			
N°	PARTICOLARE	MATERIALE	SPECIFICA
1	CORPO	ACCIAIO INOX	AISI 316
2	TERMINALE	ACCIAIO INOX	AISI 316
3	SFERA	ACCIAIO INOX	ASTM A351 CF8M
4	ALBERO	ACCIAIO INOX	AISI 316
5	SEDE	PTFE	-
6	TENUTA CORPO	PTFE	-
7	RONDELLA REGGISPINTA	PTFE	-
8	TENUTA ALBERO	PTFE	-
9	DADO PREMISTOPPA	ACCIAIO INOX	AISI 304
10	RONDELLA	ACCIAIO INOX	AISI 304
11	DADO LEVA	ACCIAIO INOX	AISI 304
12	LEVA	ACCIAIO INOX	AISI 430
13	BLOCCO (*)	ACCIAIO INOX	AISI 430
14	PROTEZIONE	PVC	-
15	TIRANTI	ACCIAIO INOX	AISI 304
16	RONDELLA	ACCIAIO INOX	AISI 304
17	DADO ESAGONALE	ACCIAIO INOX	AISI 304
18	SPINOTTO DI FERMO	ACCIAIO INOX	AISI 304

(*) Opzionale

1.6

Caratteristiche tecniche

- Corpo in acciaio inox.
- Terminali in acciaio inox con filettatura F/F (GAS o NPT) o M/F (GAS solo per le valvole V2-M) o S.W. (solo per le valvole V-3).
- Tipologia monoblocco (V-2, V-2M) o tre pezzi (V-3).
- Passaggio totale.
- Sedi di tenuta: PTFE.
- Sfera in acciaio inox.
- Diametri disponibili dal diam. 1/4" al 3" (le V2-M solo fino 2").
- Idonee per essere installate in ogni direzione di flusso.
- Fusione del corpo e dei terminali a cera persa.
- Manovra con leva (opzionale leva lucchettabile o farfalla).
- Flangetta superiore in accordo alla ISO 5211 (solo per le valvole V-2 e V-3).
- Temperatura di esercizio: -20°C / +160°C.
- Adatte per differenti tipi di fluidi e applicazioni industriali.
- Certificate AT.EX. per le zone 1 e 21.
- Rating PN 63.
- Prove idrauliche di tenuta in accordo alla normativa ISO 5208.
- Corpo provato a 95 bar.
- Sede provata a 70 bar.

DIMENSIONI

V-2

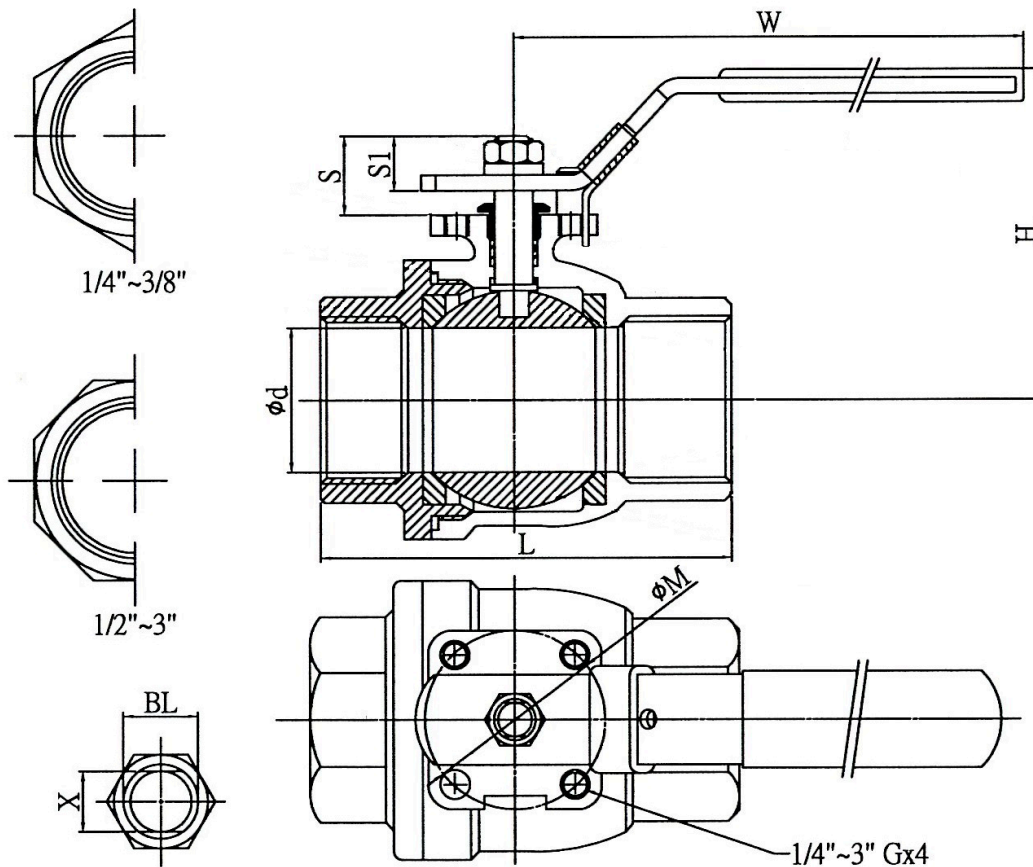

MISURA	Ød (mm)	L (mm±2)	H (mm±5)	W (mm)	S (mm)	S1 (mm)	X (mm)	BL	ISO 5211		PESO kg
									ØM	G	
1/4"	11.6	48.0	53	108	13	8.0	5.0	5/16"	36	M5	0.27
3/8"	12.8	48.0	53	108	13	8.0	5.0	5/16"	36	M5	0.26
1/2"	15.0	55.0	53	108	14	9.5	5.0	5/16"	36	M5	0.33
3/4"	20.0	63.0	63	123	21	12.5	6.5	3/8"	36	M5	0.50
1"	25.0	78.0	76	153	26	15.6	8.0	7/16"	42	M5	0.87
1.1/4"	32.0	90.0	82	153	22	15.6	8.0	7/16"	42	M5	1.21
1.1/2"	38.0	104.0	93	163	26	16.9	9.0	1/2"	50	M6	2.03
2"	50.0	125.5	100	163	23	16.9	9.0	1/2"	50	M6	2.87
2.1/2"	65.0	160.0	133	238	42	29	12.0	3/4"	70	M8	6.00
3"	80.0	185.5	150	238	42	29	12.0	3/4"	70	M8	9.70

DIMENSIONI

V-2M

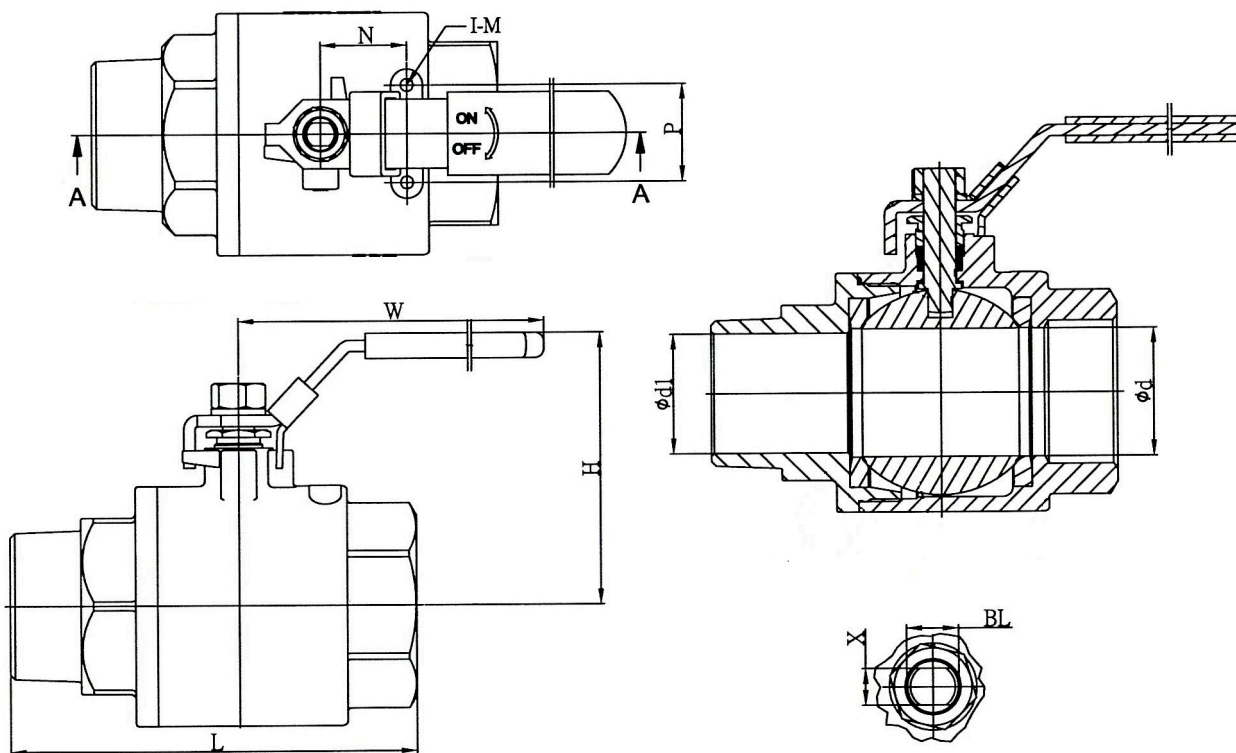

MISURA	Ød (mm)	Ød1 (mm)	L (mm±2)	H (mm±5)	W (mm)	N (mm)	P (mm)	I-M	X (mm)	BL	PESO kg
1/4"	11.6	7.0	63.0	51	98	12.5	28.5	2-M6xP1.0	5.0	5/16"	0.28
3/8"	12.8	8.5	63.5	51	98	12.5	28.5	2-M6xP1.0	5.0	5/16"	0.28
1/2"	15.0	12.5	74.0	53	98	12.5	28.5	2-M6xP1.0	5.0	5/16"	0.36
3/4"	20.0	17.5	82.0	63	118	21.0	34.8	2-M6xP1.0	6.5	3/8"	0.58
1"	25.0	23.8	98.5	77	143	22.5	34.8	2-M6xP1.0	8.0	7/16"	0.90
1.1/4"	32.0	30.8	112.4	82	143	23.5	38.1	2-M6xP1.0	8.0	7/16"	1.38
1.1/2"	38.0	36.6	126.4	98	173	23.5	38.1	2-M6xP1.0	9.0	1/2"	2.16
2"	50.0	47.5	151.7	106	173	23.5	38.1	2-M6xP1.0	9.0	1/2"	3.38

DIMENSIONI

V-3

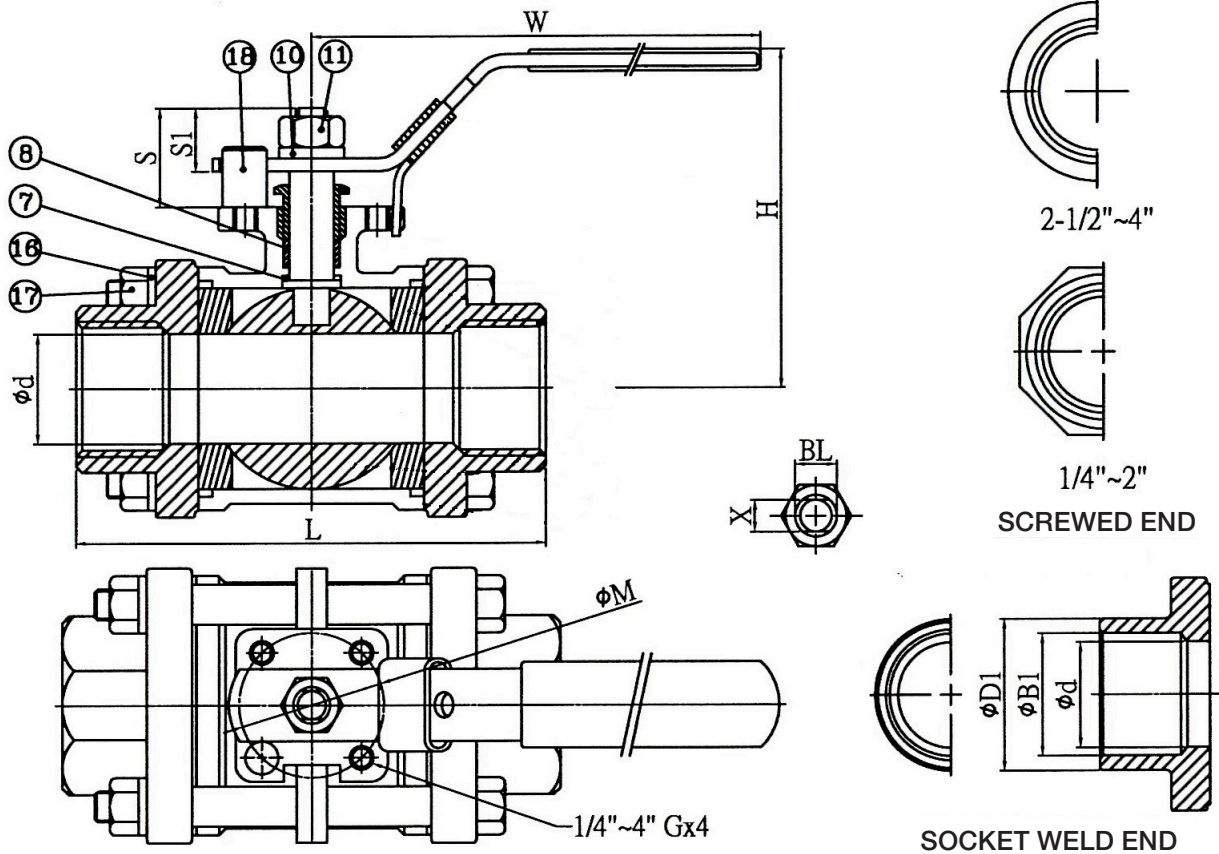

MISURA	Ød (mm)	L (mm±2)	H (mm±5)	W (mm)	S (mm)	S1 (mm)	ØB (mm)	ØB1 (mm)	ØD (mm)	ØD1 (mm)	X (mm)	BL	ISO 5211		PESO kg
													ØM	G	
1/4"	11.6	58.0	54	108	11.6	7.0	12.0	14.1	18.0	19.0	5.0	5/16"	36	M5	0.43
3/8"	12.8	58.0	54	108	11.6	7.0	14.0	17.6	18.0	22.5	5.0	5/16"	36	M5	0.42
1/2"	15.0	62.0	58	108	13.5	8.8	17.1	21.7	22.0	27.0	5.0	5/16"	36	M5	0.54
3/4"	20.0	75.6	64	123	18.0	12.5	22.5	27.1	27.5	33.0	6.5	3/8"	36	M5	0.73
1"	25.0	84.8	76	153	21.3	15.6	28.0	33.8	33.5	40.0	8.0	7/16"	42	M5	1.06
1.1/4"	32.0	100.0	82	153	22.8	15.6	35.5	42.6	44.0	48.8	8.0	7/16"	42	M5	1.67
1.1/2"	38.0	115.0	94	163	25.6	16.9	43.0	48.7	50.0	55.0	9.0	1/2"	50	M6	2.43
2"	50.0	132.0	102	163	23.6	16.9	53.0	61.1	61.5	67.2	9.0	1/2"	50	M6	3.50
2.1/2"	65.0	165.0	132	238	40.9	29.0	65.0	76.9	76.0	86.4	12.0	3/4"	70	M8	7.40
3"	80.0	183.0	149	238	37.9	29.0	80.0	89.5	92.0	103.0	12.0	3/4"	102	M10	12.30

DIAGRAMMI PRESSIONE/TEMPERATURA

V-2

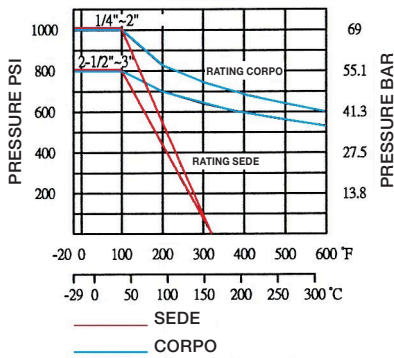

V-2M

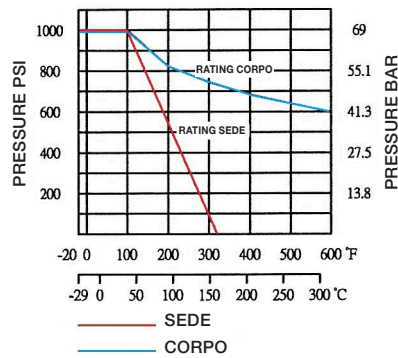

V-3

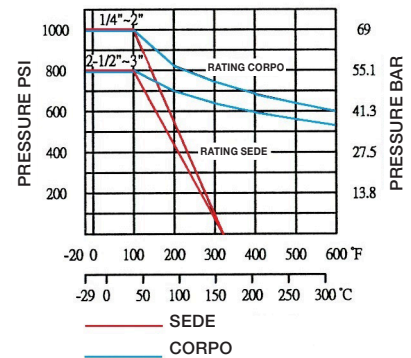

MOMENTO TORCENTE

MOMENTO TORCENTE (Nm)									
DN	V-2			V-2M			V-3		
	5 BAR	34 BAR	69 BAR	5 BAR	34 BAR	69 BAR	5 BAR	34 BAR	69 BAR
1/4"	4.0	4.0	4.0	4.0	4.0	4.0	4.0	4.0	4.0
3/8"	4.0	4.0	4.0	4.0	4.0	4.0	4.0	4.0	4.0
1/2"	5.4	5.4	5.8	5.4	5.4	5.8	5.4	5.4	5.8
3/4"	7.4	7.6	8.0	7.4	7.6	8.0	7.4	7.6	8.0
1"	10.4	11.3	13.0	10.4	11.3	13.0	10.4	11.3	13.0
1.1/4"	13.5	15.0	17.5	13.5	15.0	17.5	13.5	15.0	17.5
1.1/2"	18.0	21.0	25.0	18.0	21.0	25.0	18.0	21.0	25.0
2"	25.0	30.0	37.0	25.0	30.0	37.0	25.0	30.0	37.0
2.1/2"	48.0	68.0	95.0	-	-	-	48.0	68.0	95.0
3"	75.0	95.0	125.0	-	-	-	75.0	100.0	125.0

2.1/2" e 3" sono stati testati a 55 BAR